



Luis Martínez (ESR 02)

Diversified Power Generators for Smart Buildings with Advanced Power Sharing Capabilities



The EU Framework Programme
for Research and Innovation

HORIZON 2020



INNOVATIVE
TRAINING
NETWORKS



@MSCActions

ETN 955614

Marie Skłodowska-Curie Actions (MSCA)
Innovative Training Networks (ITN)
H2020-MSCA-ITN-2020

Renewable generation capacity by energy source

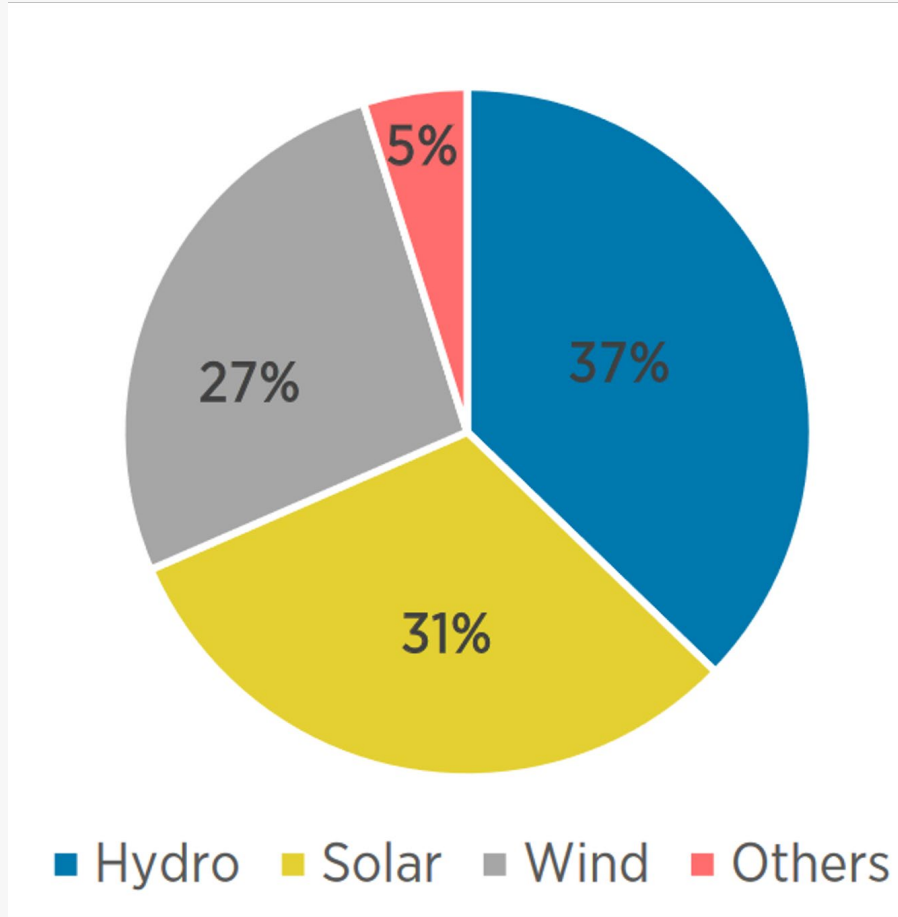

Generated with Gemini 3.

Source: ©IRENA

<https://www.irena.org/Publications/2023/Mar/Renewable-capacity-statistics-2023>

Solar PV capacity (GW)

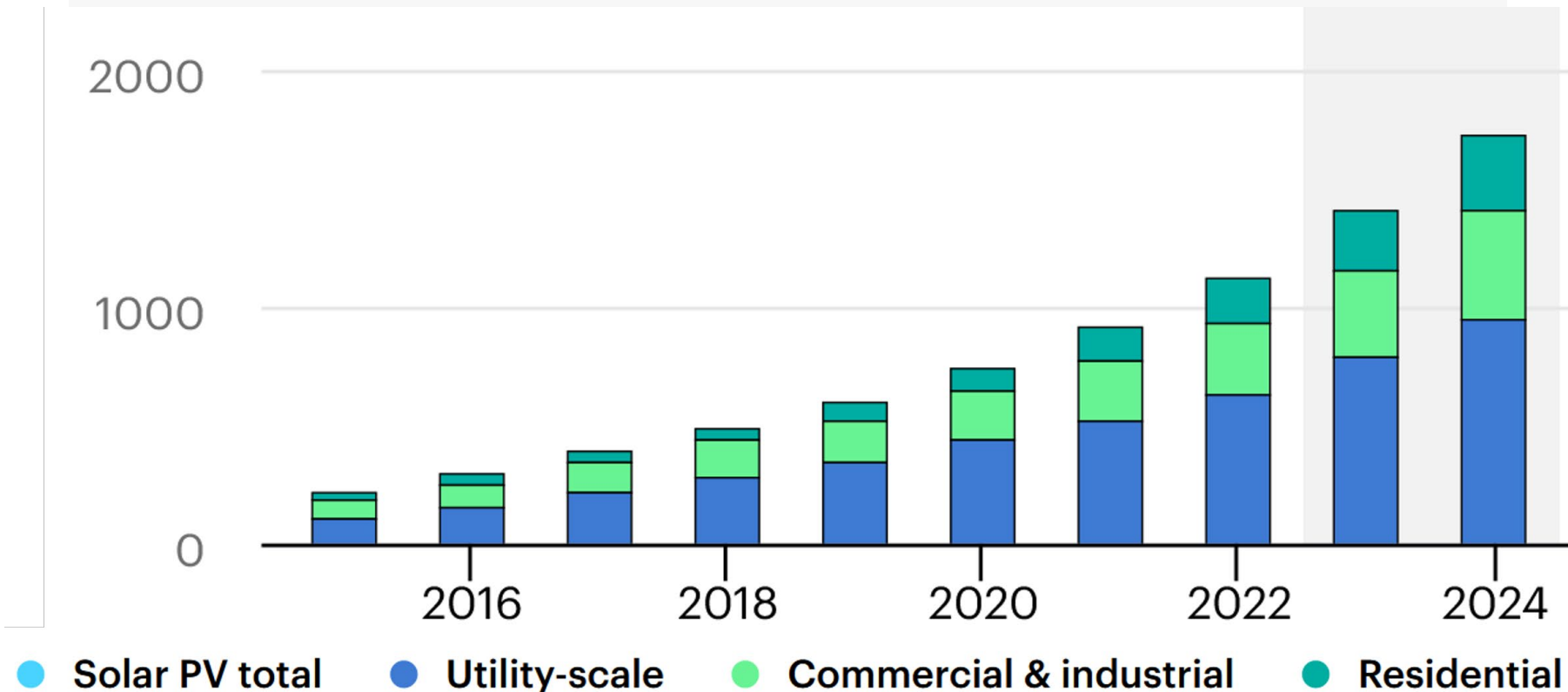

Source: ©IRENA <https://www.irena.org/Publications/2023/Mar/Renewable-capacity-statistics-2023>

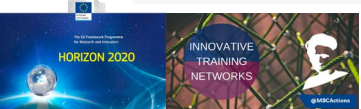

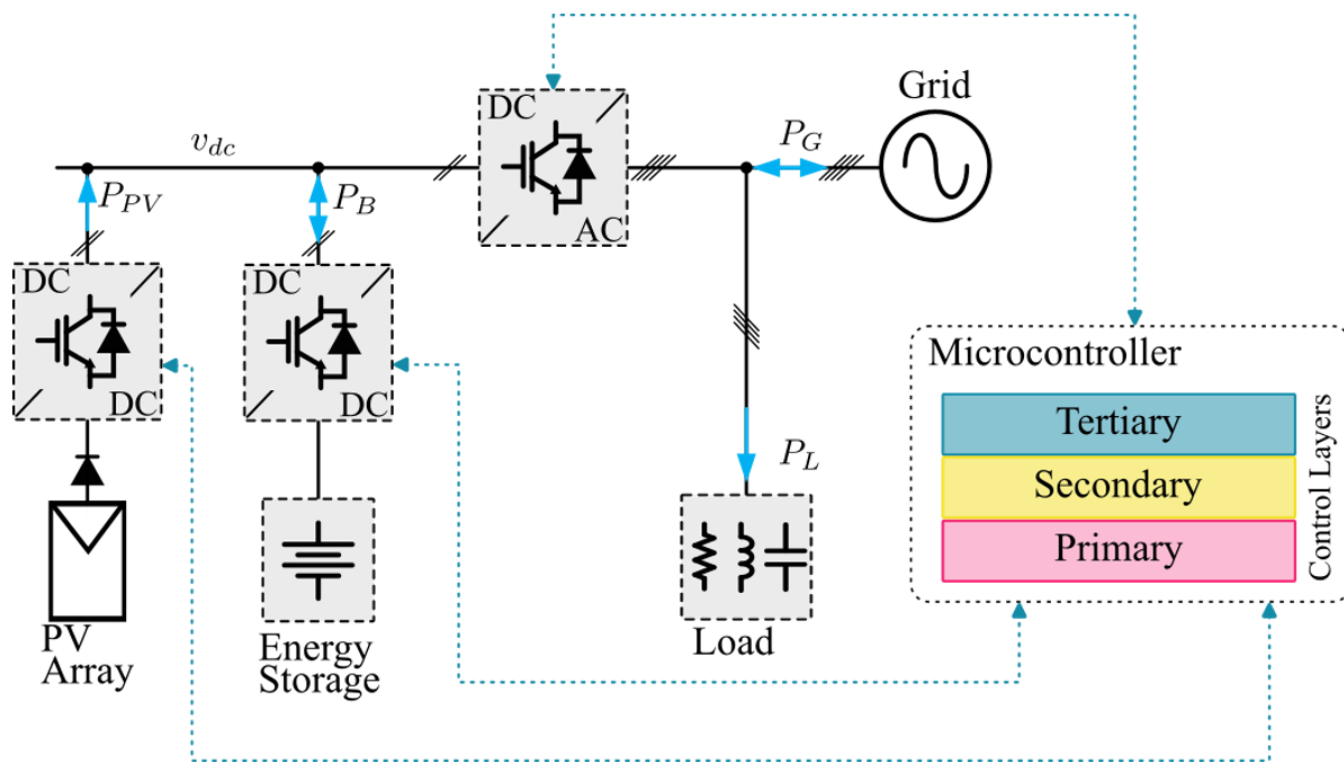

PV as renewable source supported by Li-ion battery

Focus on power and energy management

Validation of control layers and system coordination

1. Averaged simulation model

Switching and averaged model comparison [C1]

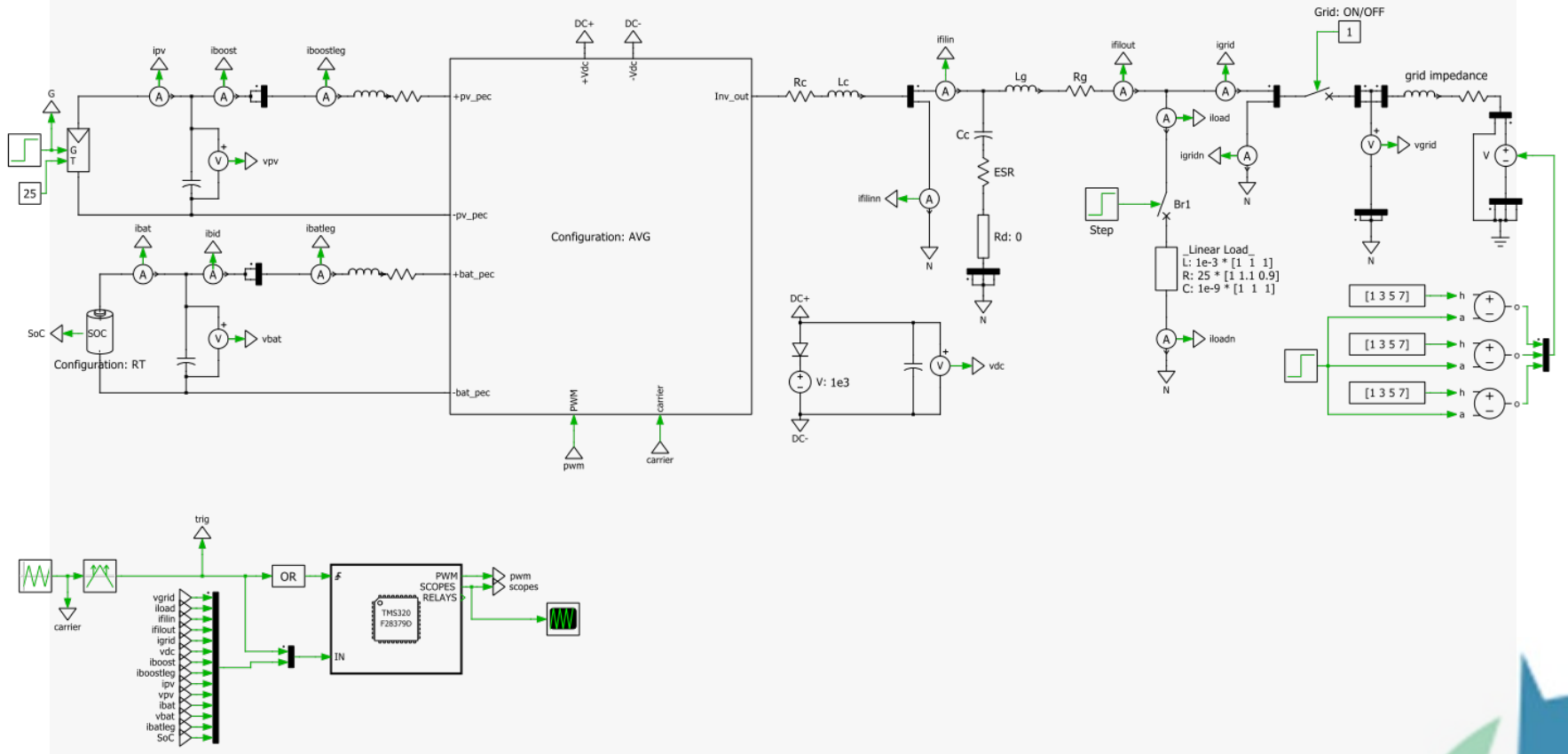

Improvement of current control (CCM/DCM) [C2]

Soft-start method for PV system [C3]

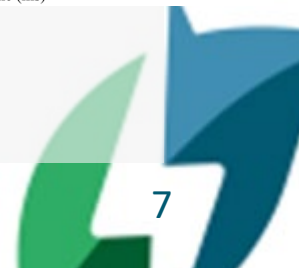
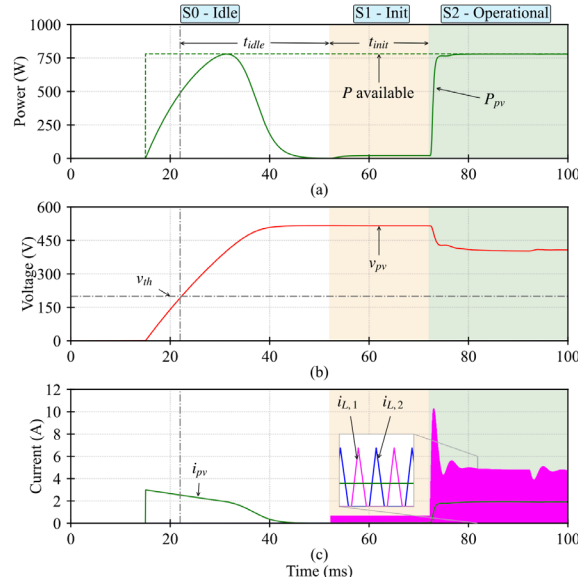
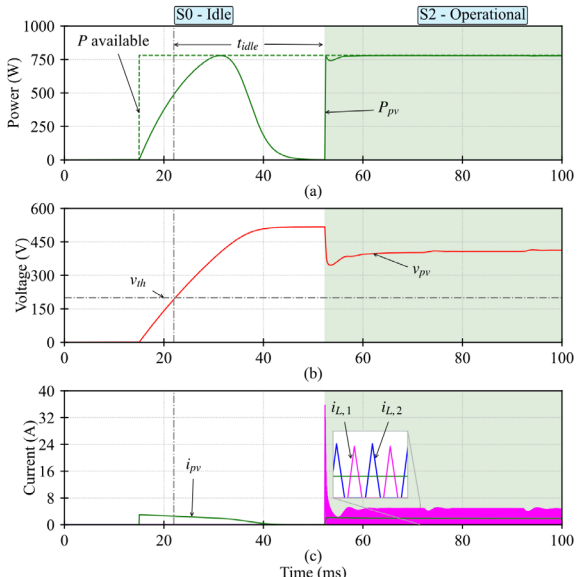
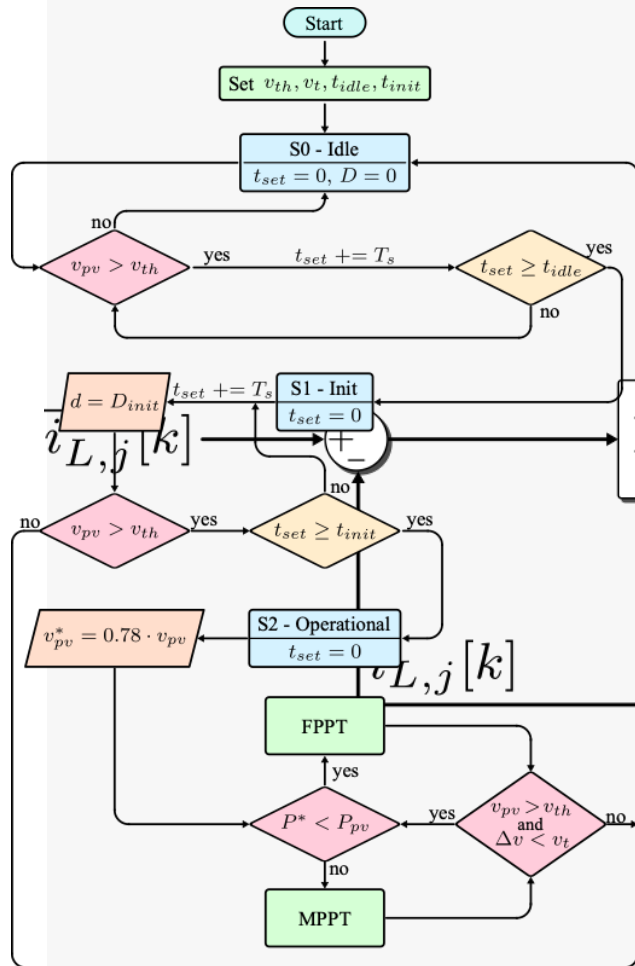

Grid Active Power Control [C4]

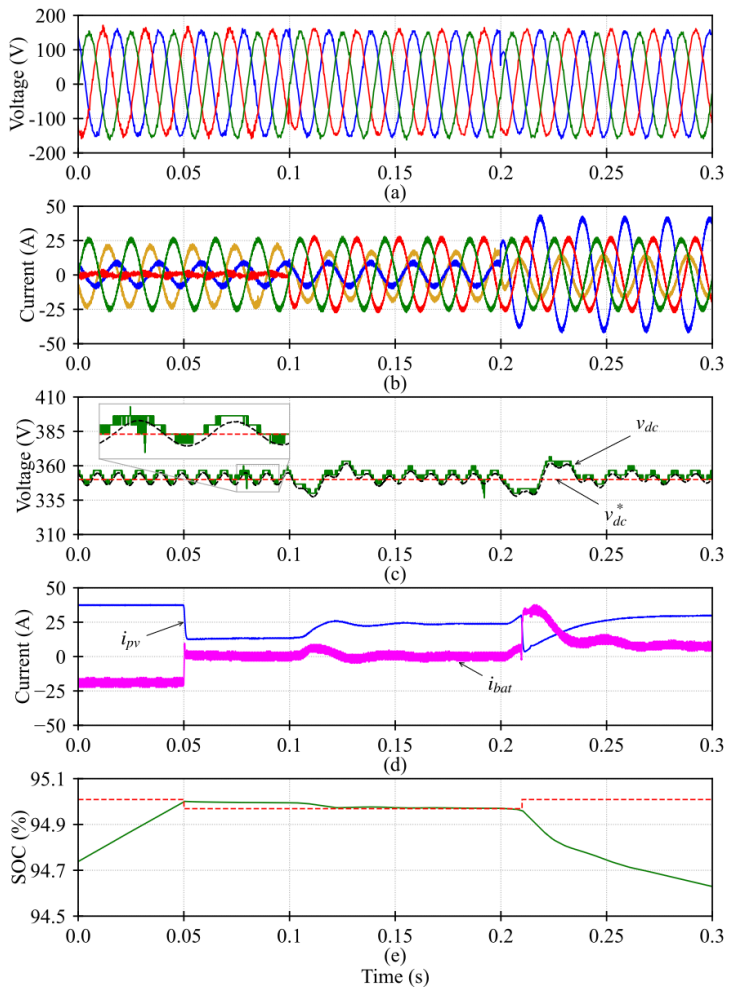

Power balance in Standalone Mode [J2]

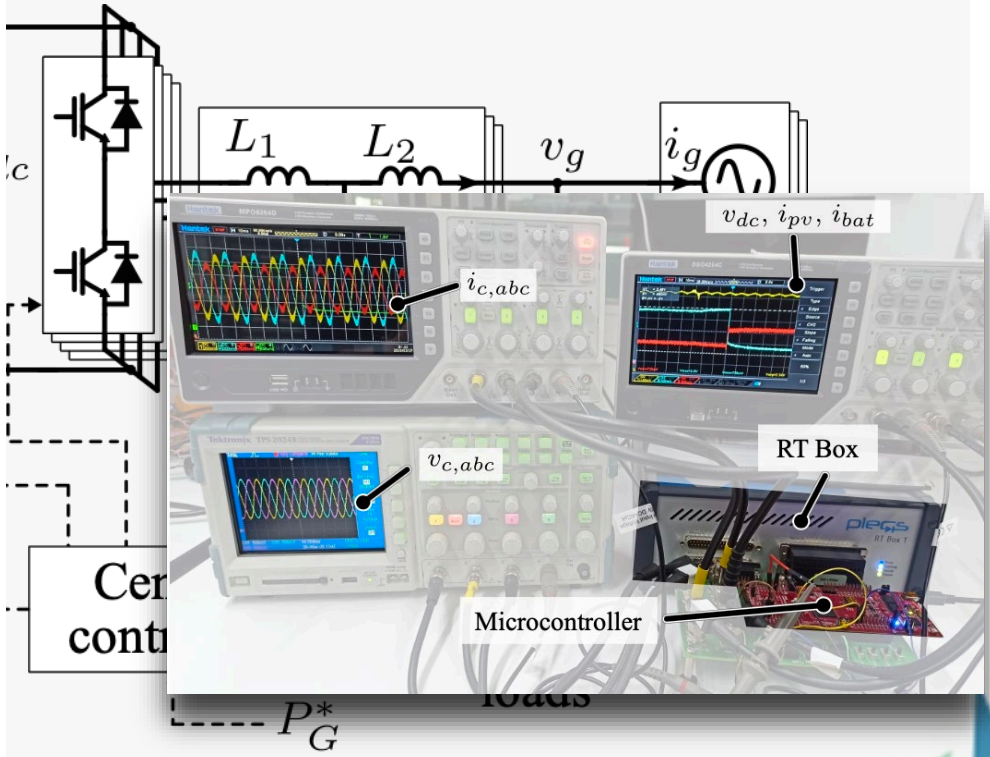

Individual tests of converters

Experimental validation of the system

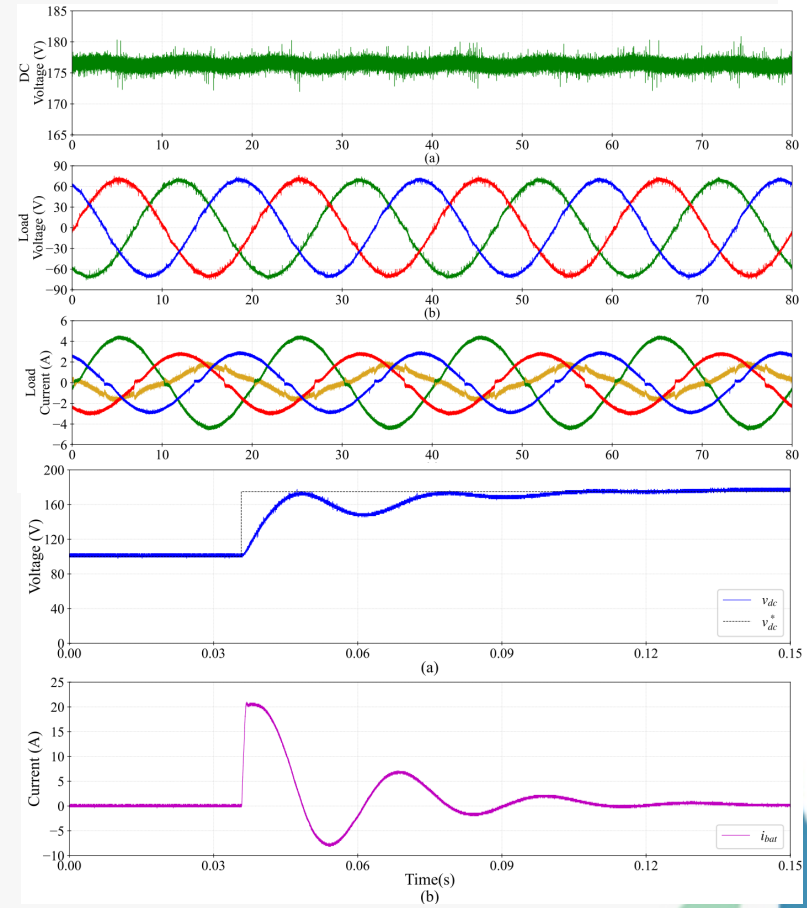
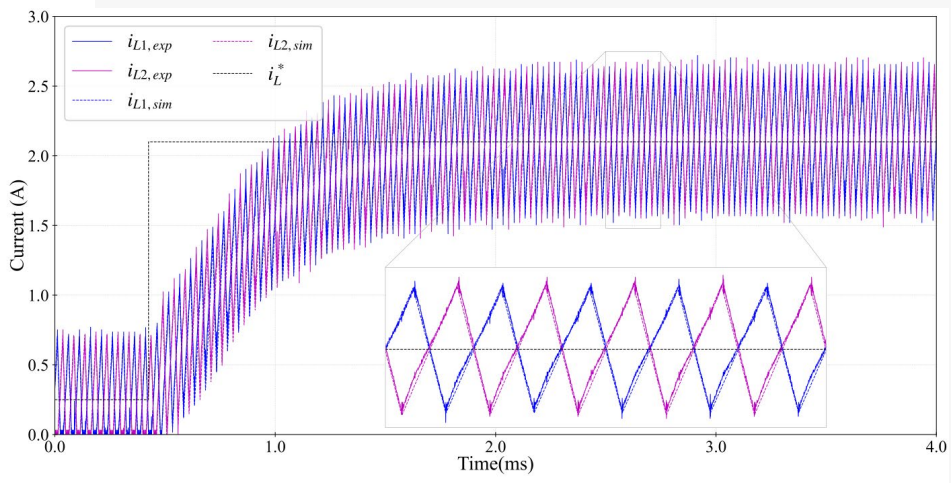
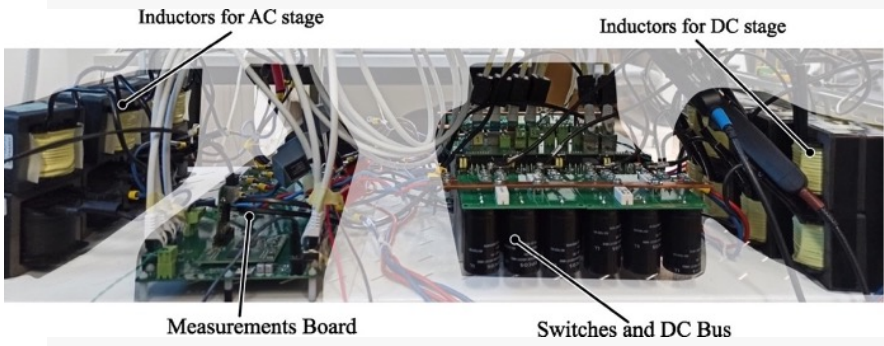

5. Energy Management Strategies

Simulation of GA based EMS [J1]

Comparison of GA and Shortest-path based optimization

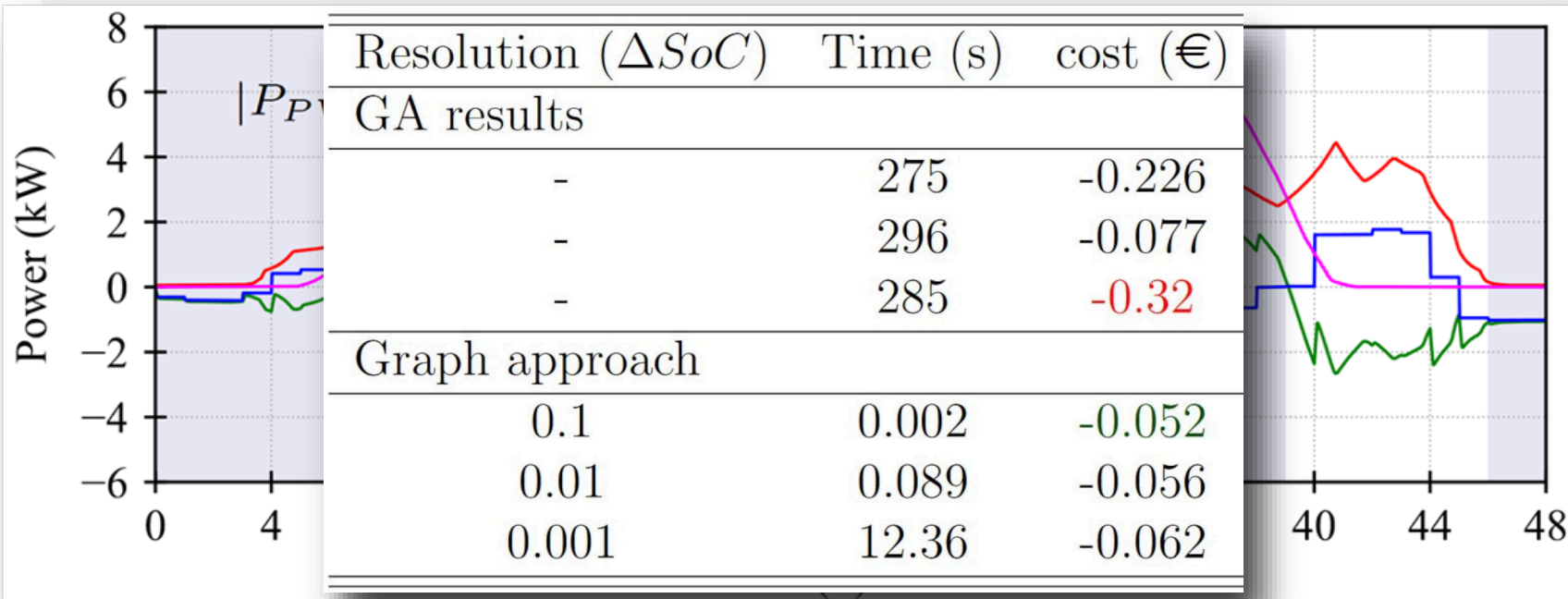

Live Tour

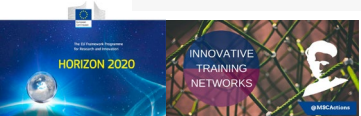

ETN 955614
Marie Skłodowska-Curie Actions (MSCA)
Innovative Training Networks (ITN)
H2020-MSCA-ITN-2020

Research and Training Network for
Smart and Green Energy Systems and Business Models

Warsaw University of Technology



University of Extremadura



Aalborg University

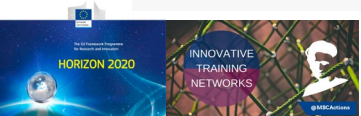

ETN 955614

Marie Skłodowska-Curie Actions (MSCA)
Innovative Training Networks (ITN)
H2020-MSCA-ITN-2020

Research and Training Network for
Smart and Green Energy Systems and Business Models

Thank you!